

NO.	NOTES
1	<b>WIRING LEGEND:</b> DISTANT TERMINATING AREA DISTANT TERMINATING DESIGNATION COLOR CODE PQ(8)-O
2	<b>WIRE COLOR CODE:</b> W-WHITE BL-BLUE BK-BLACK BR-BROWN O-ORANGE P-PURPLE Y-YELLOW S-SLATE G-GREEN R-RED
3	TERMINALS DESIGNATED ( ) DO NOT APPEAR ON COMPONENT.
4	CONNECTORS VIEWED FROM WIRED END.
5	* DENOTES 18AWG WIRE. ALL OTHER WIRING 24AWG.
6	FOR SCHEMATIC WIRING DIAGRAM SEE 7882WD.
7	<b>ASSOCIATED UNIT ACTUAL WIRING DIAGRAMS</b> 7885 WD KEYBOARD-UK800,804 7886WD MOTOR 7887WD TAPE READER-UX800,801 7888WD CALL CONTROL UNIT-UCC-3 4970WD SELECTOR MAGNET DRIVER
8	FOR TELETYPE PERSONNEL REFERENCE SPECIFICATION 67135-FRICTION FEED SPECIFICATION 60,767S-SPROCKET FEED
9	182678 CABLE ASSEMBLY IS USED ON UP800,801 PRINTER ASSEMBLIES. 182681 CABLE ASSEMBLY IS USED ON UP802,803,820 PRINTER ASSEMBLIES.
10	WIRING OF MATING CONNECTOR RECEPTACLE-3 ON THE UCC-3 CALL CONTROL UNIT CHANGED TO ACCOMMODATE UX-801 AUTOMATIC READER CONTROL FACILITIES CABLE ASSEMBLY (STRAP) USED ON UP-800,801 KSR ONLY. ON EARLY UNITS IF STRAP IS USED, CONNECTOR POSITION 3 WILL CONTAIN A MALE TERMINAL.
11	THESE COMPONENTS USED ON UP801, 803,820 PRINTER ASSEMBLIES ONLY FOR UX800 (MANUAL) OR UX-801 (AUTOMATIC) READER OPERATION. (ALSO SHOWN ON READER 7887WD.)
12	182691 CABLE ASSEMBLY IS USED ON ALL PRINTER ASSEMBLIES EXCEPT WHEN EQUIPPED WITH AUTOMATIC READER OPTION WHICH REQUIRES USE OF 183123 CABLE ASSEMBLY. SEE NOTE 13-A,14.
13	<b>MODIFICATIONS TO UP 801, 803 PRINTER ASSEMBLIES TO PROVIDE AUTOMATIC READER CONTROL OPTIONS:</b> 13-A- USE 183128 MODIFICATION KIT TO ADD ASSOCIATED PARTS AND X-ON, X-OFF FUNCTION BOX CONTACT ASSEMBLIES TO PROVIDE AUTOMATIC CONTROL READER. (183123 CABLE ASSEMBLY IS USED) 13-B- USE 182290 MODIFICATION KIT TO ADD ASSOCIATED PARTS AND TD CALL IN FUNCTION BOX CONTACT ASSEMBLY MODIFIED AS PER 183128 MODIFICATION KIT-NOTE-13-A 13-C- USE 182291 MODIFICATION KIT TO ADD ASSOCIATED PARTS AND WRU FUNCTION BOX CONTACT ASSEMBLY MODIFIED AS PER 183128 MODIFICATION KIT-NOTE-13-A ON PRINTER ASSEMBLIES WITHOUT THE WRU CONTACT ASSEMBLY THE Y WIRE FROM CONNECTOR PLUG NO 3 TERMINAL 11 WILL BE ASSEMBLED TO X-OFF CONTACT TERMINAL (5) AND THE BK WIRE FROM WRU CONTACT TERMINAL (15) TO X-OFF CONTACT TERMINAL (5) IS NOT USED.

14. THESE COMPONENTS ARE STANDARD EQUIPMENT ON THE UP820 PRINTER UNIT.

15. APPLIES TO UNITS CONTAINING PRINT NONPRINT OPTION. 183986 MODIFICATION KIT.

16. **WIRING STATUS:**  
 RECTANGULAR BOX INDICATES HISTORY OF WIRING CHANGES  
 B - DENOTES WIRING BEFORE THE CHANGE DESCRIBED BY THE DESIGNATED NOTE ENTERED THE PRODUCT.  
 A - DENOTES WIRING AFTER THE CHANGE DESCRIBED BY THE DESIGNATED NOTE ENTERED THE PRODUCT.

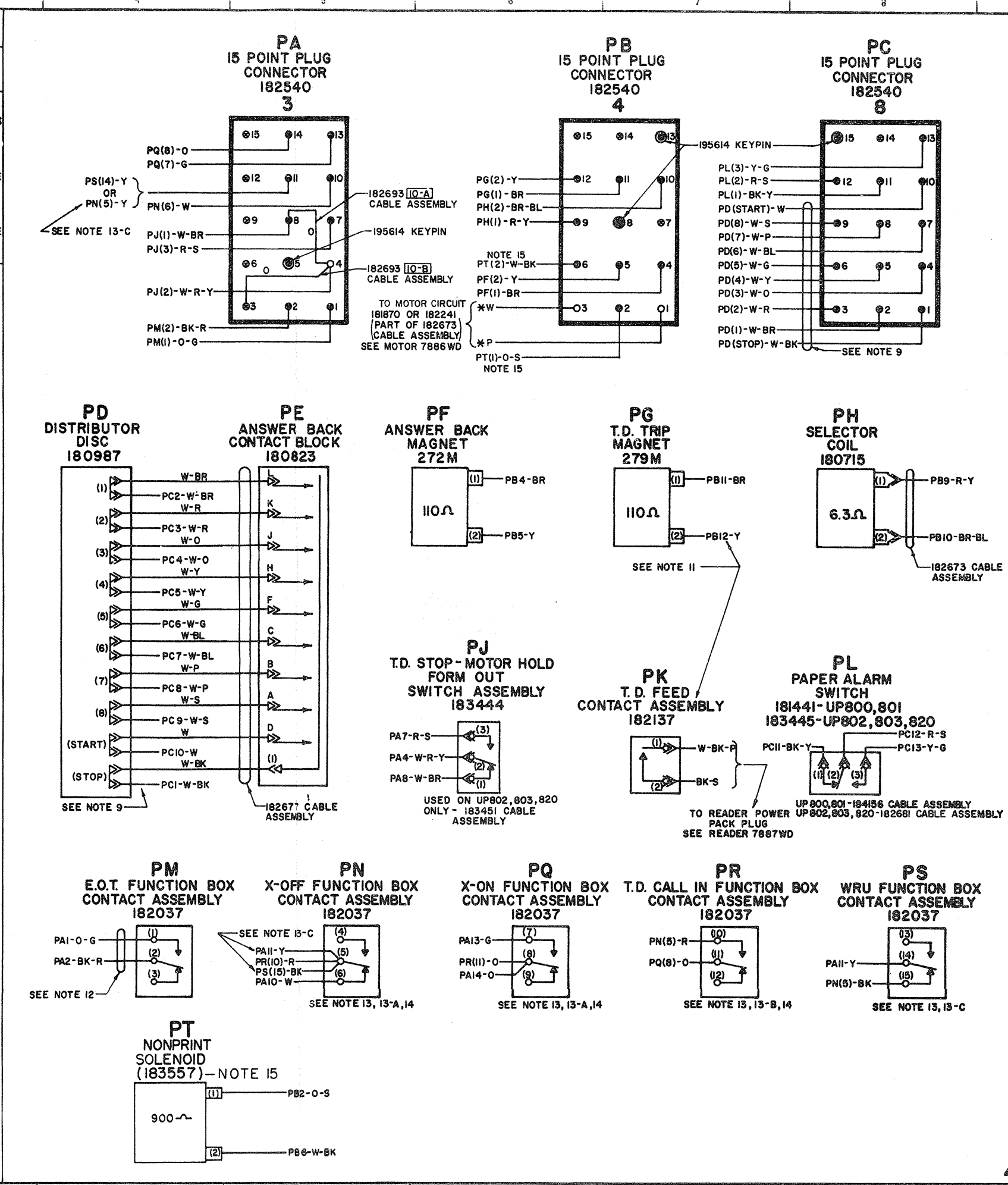

7884 WD

REVISIONS		
ISSUE	DATE	AUTH. NO.
1	2-23-66	17470-R
2	3-29-66	90790
3	6-7-66	89162
4	11-3-66	92300 RC

ACTUAL WIRING DIAGRAM FOR MODEL 35 S LEVEL KSR-ASR PRINTER

UP-800-KSR FRICTION FEED  
 UP-801-ASR FRICTION FEED  
 UP-802-KSR SPROCKET FEED  
 UP-803-ASR SPROCKET FEED  
 UP-820-ASR SPROCKET FEED

APPROVALS	
D AND R	E OF M
E-NUMBER	
PROD. NO. 7884 WD	
DATE 9-20-68	
P.D. FILE NO. G.A152AA	
DRAWN R.H.S.	CHKD. J.S.
ENSD. J.W.S.	APPD. J.S.

7884 WD